

# SANELA



URINAL FLUSH



Installation  
& maintenance  
instructions.

**SPL**

## General Information

- Designed for indoor use only. Do not expose to elements of nature.
- All plumbing and electrical connection must be made in accordance with AS/NZ3500 and installation with AS/NZ3500.2.

## Warnings

- Read all instructions before attempting to install this system. It is recommended a qualified & registered plumber completes the install.
- Ensure pipe work is thoroughly flushed before installing the flush control (internal solenoid). Solenoid components are susceptible to debris and require additional flushing compared to a standard plumbing fixture.
- Consideration should be given to any regulations relating to an air gap, an air break or double check valve to protect against back flow.

# Operating Instructions and Parts Manual

Please read carefully before attempting to assemble, install, operate or maintain the product described. Protect yourself and others by observing all safety information. Failure to comply with instructions could result in personal injury and/or property damage. Retain instructions for future reference.

## Sanela Urinal Flush Control

Sensor operated flush control for single urinal. Non touch infrared system reacts to user attendance within active range and flushes once the user has left. High quality electronics combined with elegant aesthetics.

## Specifications

Power Supply	Mains 230V AC, 50Hz (input) 24V (output)
Location	Wall mounted above the urinal
Control	Infra-red sensor
Stainless Steel Cover	170 x 170 x 10mm
Mounting Box	140 x 140 x 75mm
Operating Voltage	Mains 24V D, 7W
Active Range	0.6 - 0.75 m - system reacts to user in front of urinal at max distance of 0.7m & min stay time of 7.5secs
Flush Cycles	Adjustable 0.5 secs - 15.5secs Hygiene Flush: 24hrs after last use
Recommended Pressure	0.1 - 0.6 Mpa (1-6 Bar)
Rate of Flow	18 L/min (inf. Data) - Possible to regulate flow via ball valve
Water Inlet	Male thread G 3/4"
Water Outlet	Male thread G 3/4"
Warranty	24 months
Product Code	SUI02AC

## Planning

- Ensure an appropriate piping design (sizing etc). This will eliminate issues arising from flow, pressure and water hammering.
- Where appropriate install necessary filters, water hammering arrestors and water pressure reducing valves (recommended pressure 1 to 6 bar). This will minimise future maintenance.

# Components

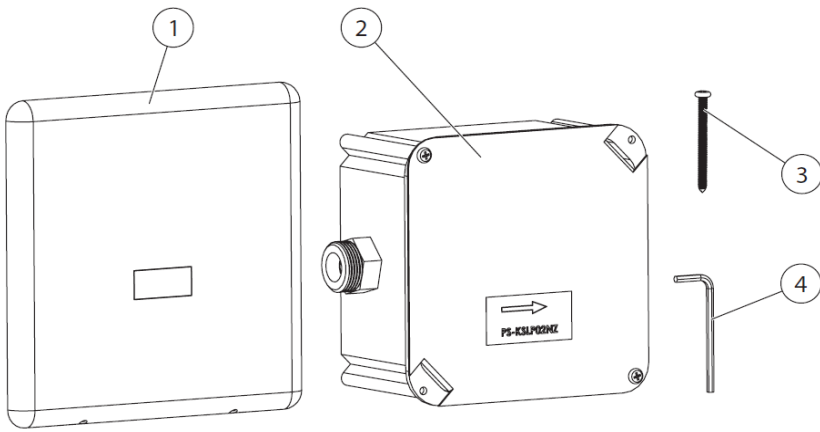

1	Stainless steel cover
2	Mounting box with integrated power supply
3	Screw x 4
4	Allen key

# Standard Functions

**1.**

Person stays within active range for minimum stay of 7.5secs

**2.**

Water flows after person leaves active range

**3.**

Hygiene flush activates automatically 24 hourly

sieve dimension  $\le 90 \mu\text{m}$

Operating pressure range  
0,1 - 0,6 MPa

**FACTORY SETTINGS**  
0.6 - 0.75m

**0,5 - 15,5 sec**

**FACTORY SETTING**  
3 SECOND FLUSH TIME

# Installation

## Important

To be installed in accordance with all NZ electrical regulations. It must be carried out by a qualified professional.

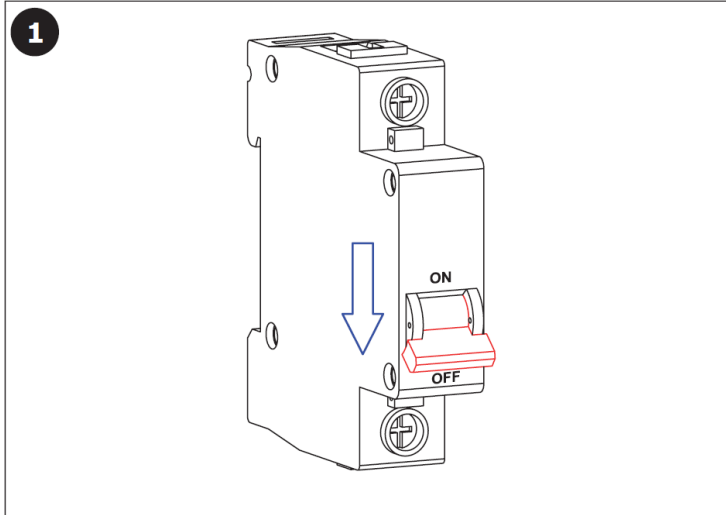

Ensure mains power supply is off.

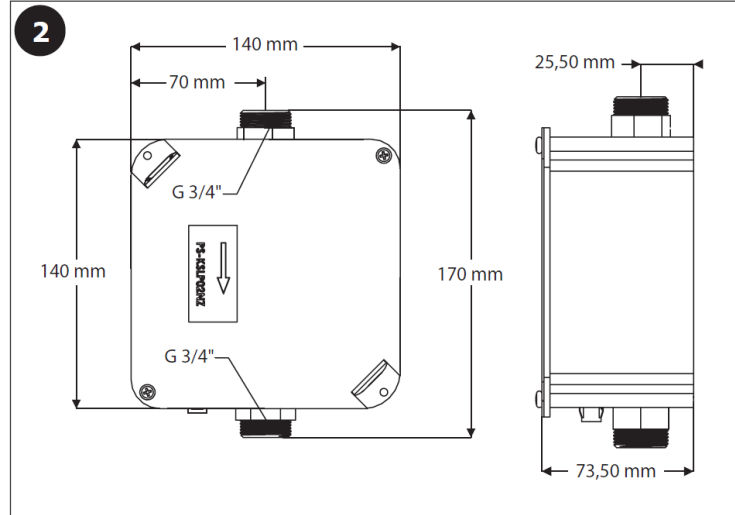

Ensure piping arrangement aligns with water inlet/outlet.

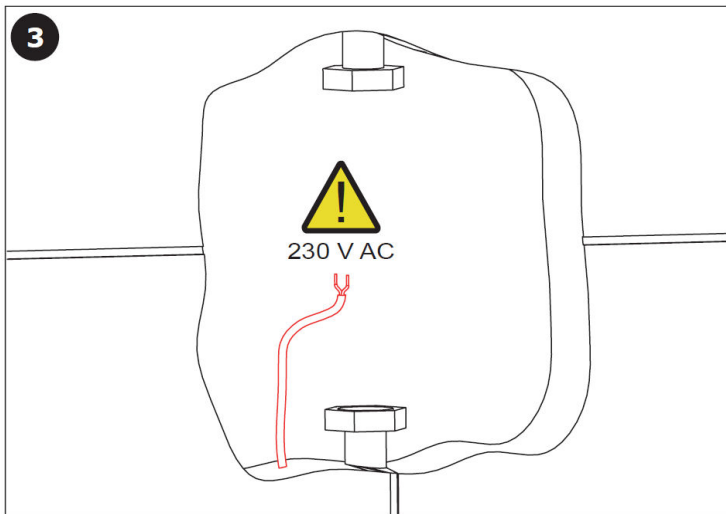

Make certain a power supply connection has been allowed for.

Note: please ensure pipework has been flushed thoroughly.

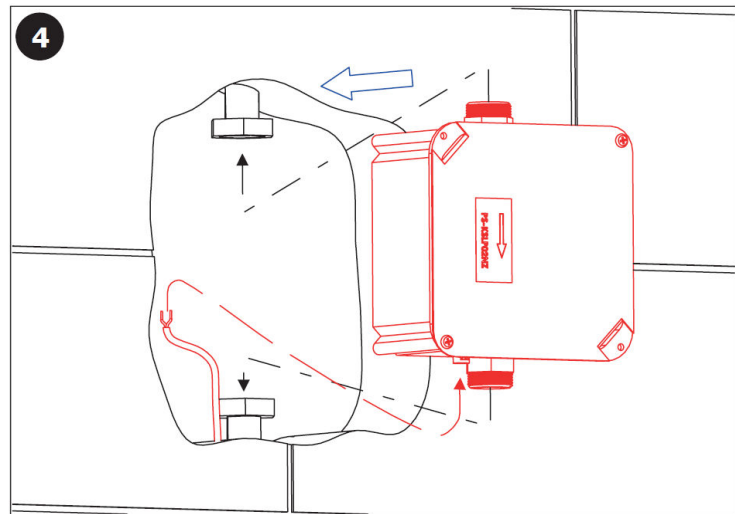

Pass mains (230V) power supply into mounting box via grommet.

Connect pipework securely.

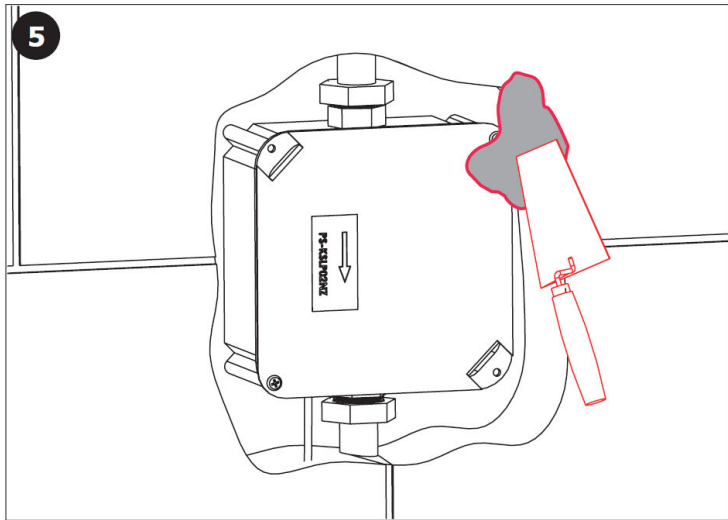

Reinstate the mounting surface if applicable. Mounting box should be flush with finished wall surface.

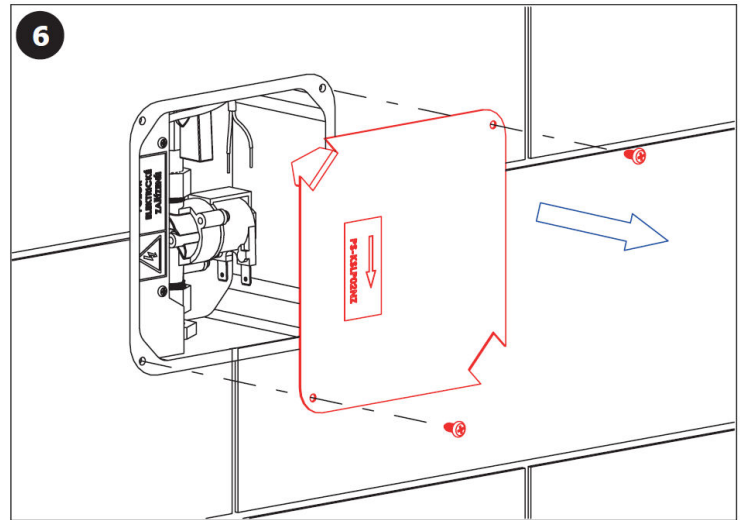

Remove cardboard cover from mounting box.

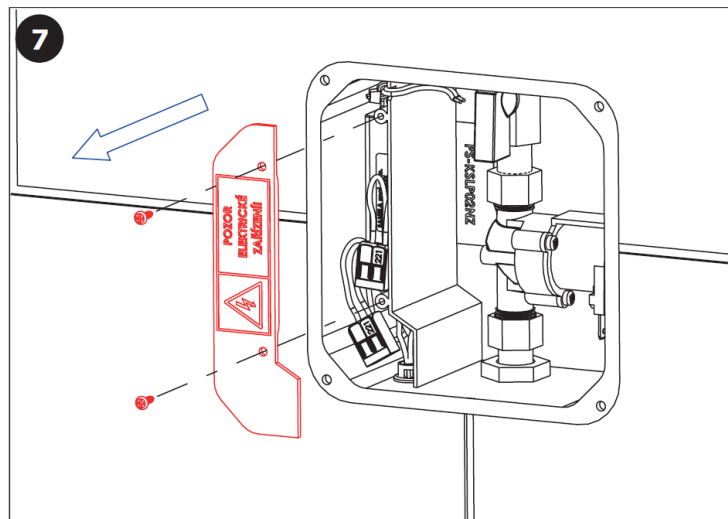

Remove safety cover to access intergrated power supply.

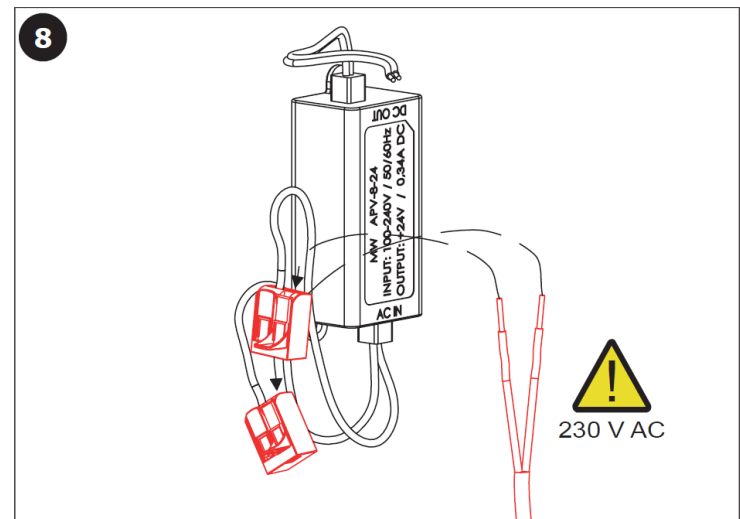

Connect external mains power supply to wago connectors - note polarity.

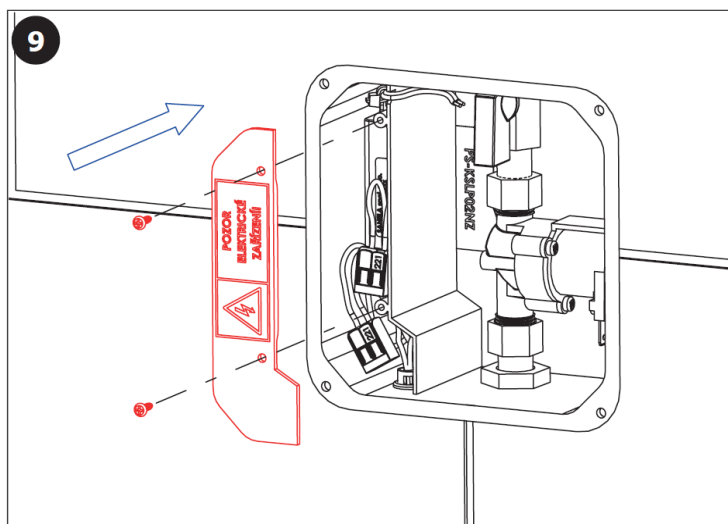

Securely replace safety cover and ensure it is sealed shut. Remember to pass the outlet supply wires through to main area of mounting box.

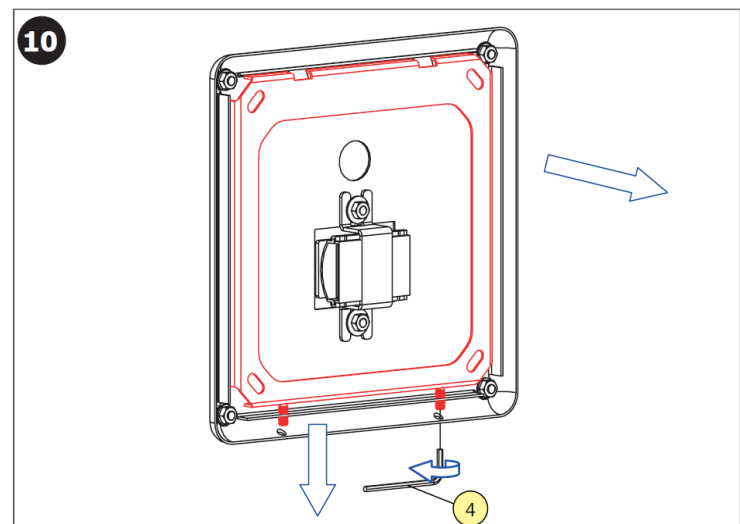

Using the allen key, remove 2 x security screws from the bottom of stainless steel cover and separate cover from plate.

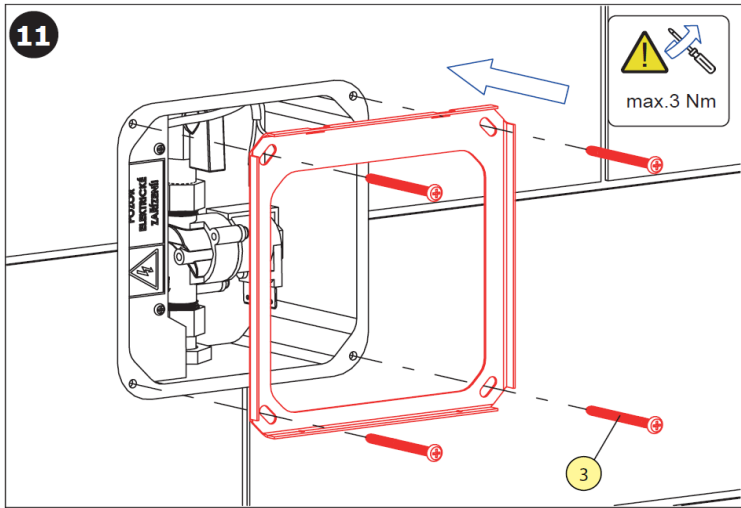

Fix plate to mounting box (4 x screws)

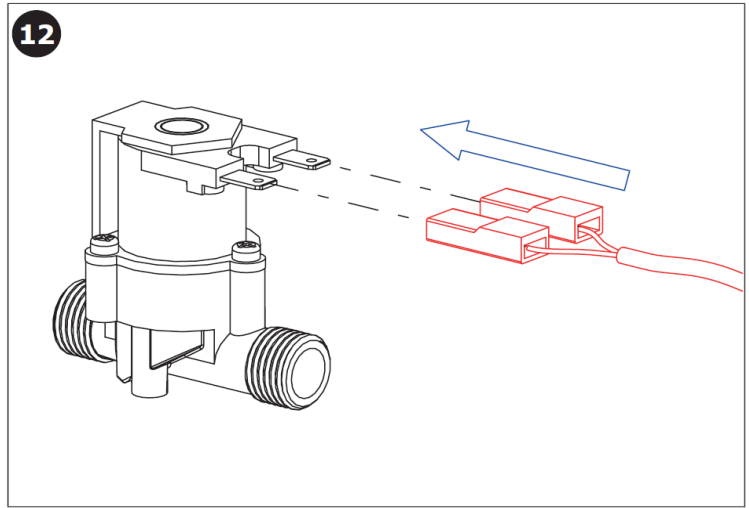

Connect electronics to solenoid valve.

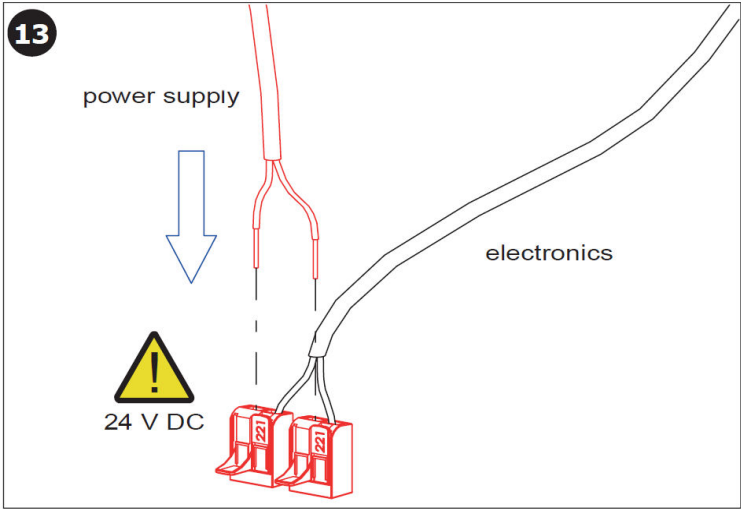

Connect mains power supply to electronics via wago connector. Note polarity.

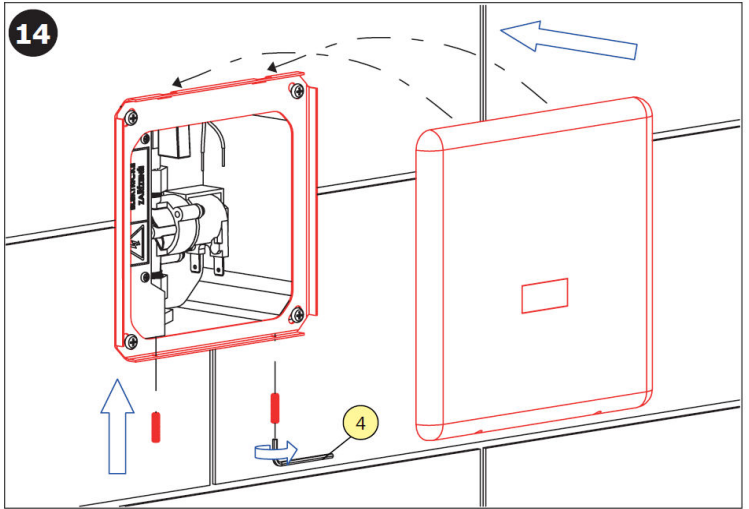

Refit stainless steel cover by carefully inserting top mounting points first, followed by tightening of 2 x security screws at the bottom - use allen key.

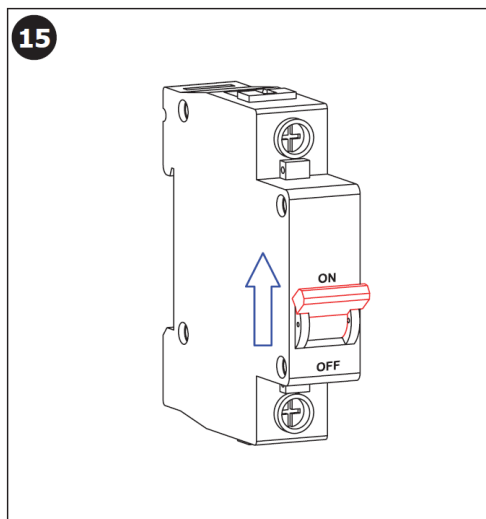

Turn power supply on. It is necessary, for the proper function, to keep the unit under constant voltage (don't connect the power supply unit behind the switch into the light circuit.)

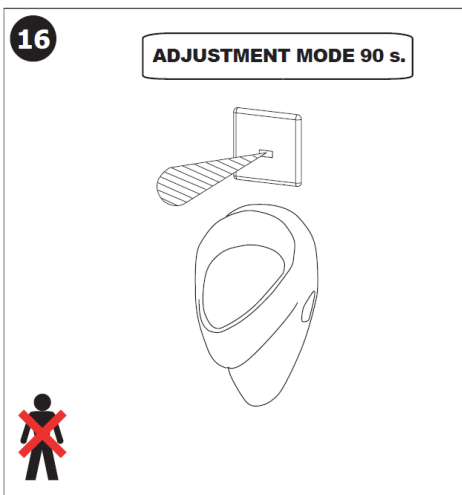

Once power on, do not come within active range for 90 seconds to allow sensor to calibrate.

# Important

Pipework is required to be flushed thoroughly prior to installation. Foreign debris may reduce level of flow and in some cases damage the solenoid valve.

- The sensor of the unit must not be obstructed.
- Avoid positioning reflective objects or surfaces in front of the sensor. This can cause false activation i.e. mirrors.
- All plumbing and electrical installation must be carried out by a qualified person and in accordance with applicable codes and regulations.

## Note:

If you require to modify any of the factory settings please request the Sanela remote SLD03.

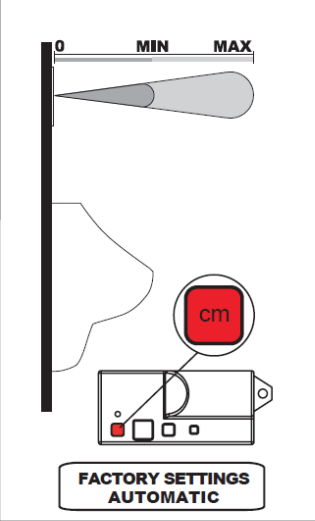
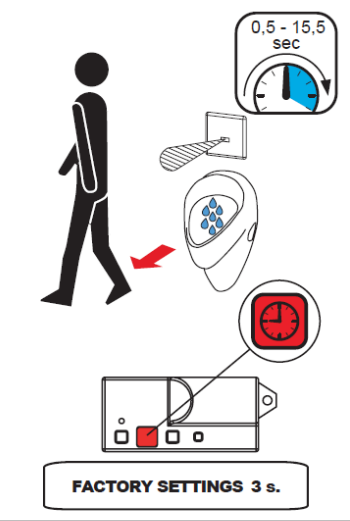
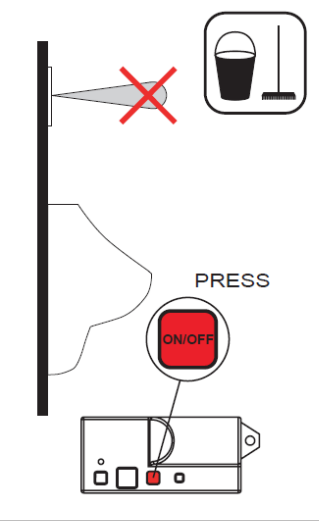
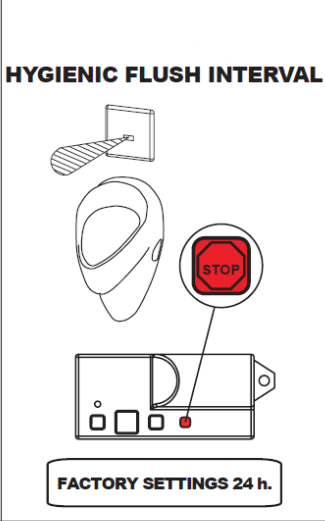
 <p>0 MIN MAX</p> <p>cm</p> <p>FACTORY SETTINGS AUTOMATIC</p>	 <p>0,5 - 15,5 sec</p> <p>3 s.</p> <p>FACTORY SETTINGS 3 s.</p>	 <p>ON/OFF</p> <p>PRESS</p>	 <p>HYGIENIC FLUSH INTERVAL</p> <p>STOP</p> <p>FACTORY SETTINGS 24 h.</p>
SLD 03: 0,3 - 0,7 m	SLD 03: 0,15 - 15,5 s.	SLD 03: ON / OFF	SLD 03: 6 / 24 / 48 / 72 h.

# Maintenance

- It is recommended that the solenoid valve and all filters be inspected for foreign debris and cleaned annually (more frequently if necessary)
- Clean cover regularly using soapy water and a soft cloth or wet sponge
- DO NOT clean cover with any abrasive material or chlorine/acid based cleaning product. This may damage the filter of the infrared sensor and/or the finish.



# Troubleshooting

Symptom	Possible Cause	Corrective Action
No water flow - sensor LED blinked when within active range	<ul style="list-style-type: none"> <li>a. Water supply</li> <li>b. Water connections</li> <li>c. Filter is clogged</li> <li>d. Faulty solenoid</li> </ul>	<ul style="list-style-type: none"> <li>a. Ensure water at source</li> <li>b. Ensure connections</li> <li>c. Clean filter (any valves and solenoid)</li> <li>d. Replace solenoid</li> </ul>
No water flow - Sensor LED did not blink when within active range	<ul style="list-style-type: none"> <li>a. Power supply</li> <li>b. Power connections to wago connectors</li> <li>c. IR sensor damaged or faulty</li> </ul>	<ul style="list-style-type: none"> <li>a. Ensure power at source</li> <li>b. Check all connections and polarity</li> <li>c. Replace IR sensor filter</li> </ul>
Water doesn't stop flowing	<ul style="list-style-type: none"> <li>a. Dirty IR sensor</li> <li>b. Obstruction in detection zone</li> <li>c. Water drop on sensor eye</li> <li>d. Ghost sensing due to reflection</li> <li>e. Debris in solenoid</li> </ul>	<ul style="list-style-type: none"> <li>a. Clean IR sensor</li> <li>b. Remove obstruction</li> <li>c. Wipe sensor</li> <li>d. Remove reflective surface or reposition</li> <li>e. Clean and/or replace solenoid</li> </ul>
Reduced flow rate	<ul style="list-style-type: none"> <li>a. Filter clogged</li> <li>b. Water supply</li> </ul>	<ul style="list-style-type: none"> <li>a. Clean filter</li> <li>b. Check pressure / flow at source</li> </ul>

# Supreme Comprehensive Warranty

Your Sanela Urinal Flush is fully guaranteed against defective materials and faulty workmanship commencing from the date of sale (according to SPL's records), subject to it being installed and maintained in accordance with the manufacturer's instructions.

SPL (2021) Limited warrants that should any part of the flush control fail within the given warranty period (24 months), it will be remedied by SPL. The flush control should be returned to SPL (2021) Limited for all warranty claims. The cost of cartage will be payable by the customer.

Due to the significant variation in tradesmen's knowledge, experience, and productivity, labour charges will NOT be accepted unconditionally. We strongly recommend contacting our office for advice before proceeding with any warranty repairs.

This warranty excludes:

- Incorrect installation, or installation that does not specifically follow the installation guidelines supplied
- Defects arising from improper installation, or incorrect electrical supply where applicable
- Failure to follow manufacturer's maintenance instructions
- Damage/Failure resulting from:
  - the use of non-authorized parts
  - authorised parts not installed in accordance with the manufacturer's instructions
  - accidental damage, negligent use, misuse, vandalism, neglect
  - damage caused either directly or indirectly by external sources (incorrect power supply, natural disaster, or insect infestation)
- Water ingress caused by property maintenance or flooding
- Negligent cleaning practices (water ingress, harmful chemical etc)

*The above includes consequential damage to any other goods, furnishings, or property.*

- Normal wear and tear and consumable parts (batteries etc)
- This warranty does not displace any statutory warranty in relation to the unit but any liability of SPL (2021) Limited under any statutory warranty will be limited to a replacement or repair of the unit or payment of the cost of such replacement or repair at the sole discretion of SPL (2021) Limited

Note:

- Warranty only extends to products purchased and installed in New Zealand.
- Contamination or poor water quality is not covered by product warranty.
- Damage to solenoid caused by inadequate flushing or excess water pressure is not covered by the product warranty.

SPL Limited  
Cambridge 3434  
New Zealand

p. +64 7 823 5790  
e. office@splwashrooms.co.nz