

SUPREME

BABY

Heavy Duty
Safe and Secure
Wall Mounted



Heavy Duty and Hygienic

Durable platforms offer excellent hygiene, resilience, and easy cleaning, making them an ideal choice for any commercial bathroom setting.

Safe and Robust

Retractable and robust fasteners ensure the safety and security of baby, keeping them protected at all times.

User-Friendly Slimline Design

Gas struts provide effortless folding during operation and discreet, secure closure against the wall when not in use.

Horizontal



| | |
|---------------------|--|
| Colour | Cream |
| Load Support | Up to 20kgs |
| Unit Weight | 11.2kg (net) |
| Material | High density polyethylene (HDPE) |
| Dimensions | 860W x 560H x 115D mm (closed) 570D (open) |
| Standards | Complys with EN12221 |
| Fixing | All fixings included + mounting template |
| Warranty | 12 Months |
| Product Code | SPBH10 |

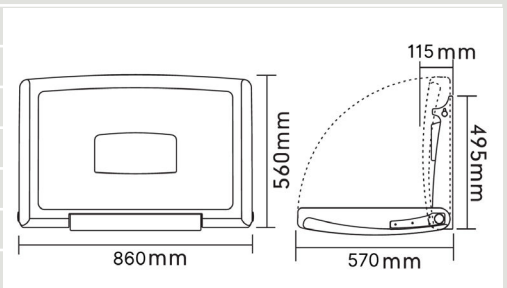

Vertical



| | |
|---------------------|--|
| Colour | Cream |
| Load Support | Up to 20kgs |
| Unit Weight | 13.2kg (net) |
| Material | High density polyethylene (HDPE) |
| Dimensions | 480W x 870H x 125D (closed) 880D mm (open) |
| Standards | Complys with EN12221 |
| Fixing | All fixings included + mounting template |
| Warranty | 12 Months |
| Product Code | SPBV20 |

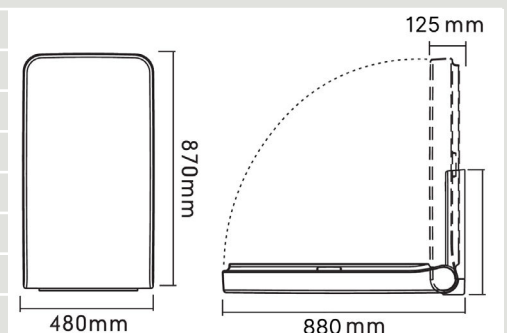

Stainless Steel Surface Mounted



| | |
|---------------------|--|
| Colour | Stainless Steel |
| Load Support | Up to 20kgs |
| Unit Weight | 23.9kg (net) |
| Material | 304 Stainless steel and polyethylene |
| Dimensions | 905W x 520H x 104D (closed) 495D mm (open) |
| Standards | Complys with EN12221 |
| Fixing | All fixings included + mounting template |
| Warranty | 12 Months |
| Product Code | SPBSSS40 |

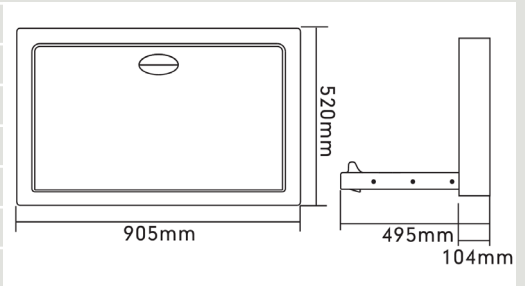

Stainless Steel Recessed



| | |
|---------------------|---|
| Colour | Stainless Steel |
| Load Support | Up to 20kgs |
| Unit Weight | 23kg (net) |
| Material | 304 Stainless steel and polyethylene |
| Dimensions | 940W x 585H x 104D mm (closed includes wall recession) 410D mm (open - wall to edge) 495mm (open includes wall recession) 10mm proud from wall when installed |
| Standards | Complys with EN12221 |
| Fixing | All fixings included + mounting template |
| Warranty | 12 Months |
| Product Code | SPBSSS40 |

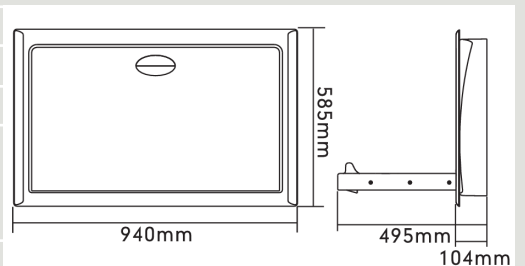

Toddler Seat



| | |
|---------------------|---|
| Colour | Grey |
| Load Support | Up to 25kgs |
| Unit Weight | 4kg (net) |
| Material | High density polyethylene (HDPE) |
| Dimensions | 340W x 510H x 145D mm (closed) 328D mm (open) |
| Standards | Complys with EN12221 |
| Fixing | All fixings included + mounting template |
| Warranty | 12 Months |
| Product Code | SPBSEAT50 |

